

0010467 Self Test EM kit
0010468 DALI Self Test EM kit

- Resisto 600mm
- Resisto 1200mm
- Resisto 1500mm

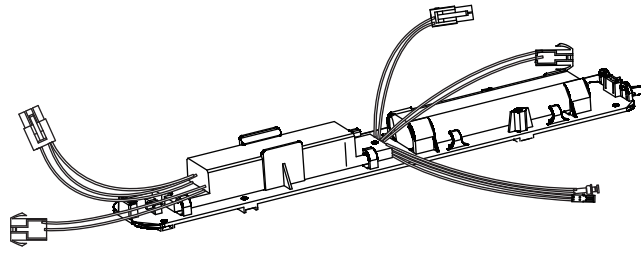

0010467 Self Test EM kit

1

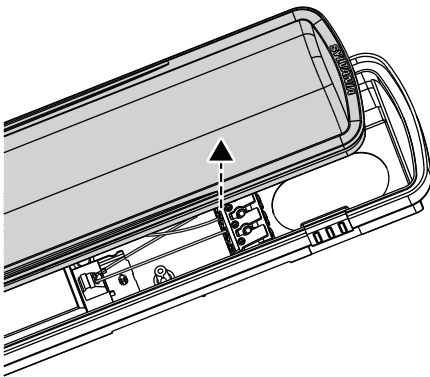

2a

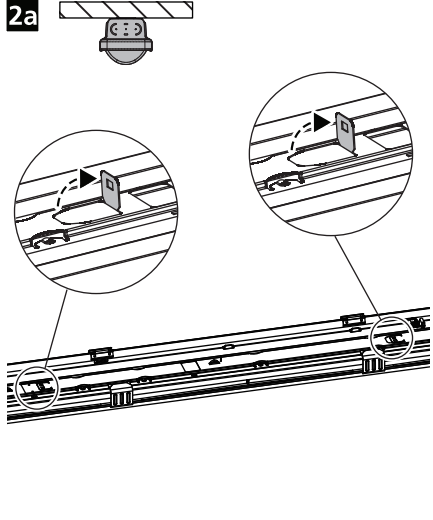

3a

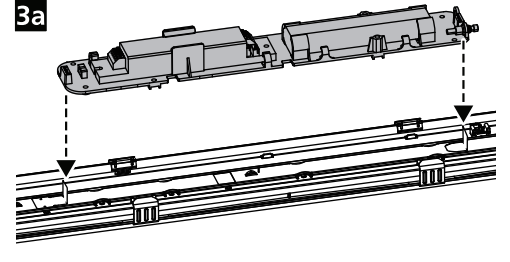

4a

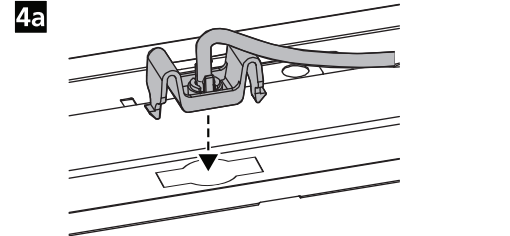

5a

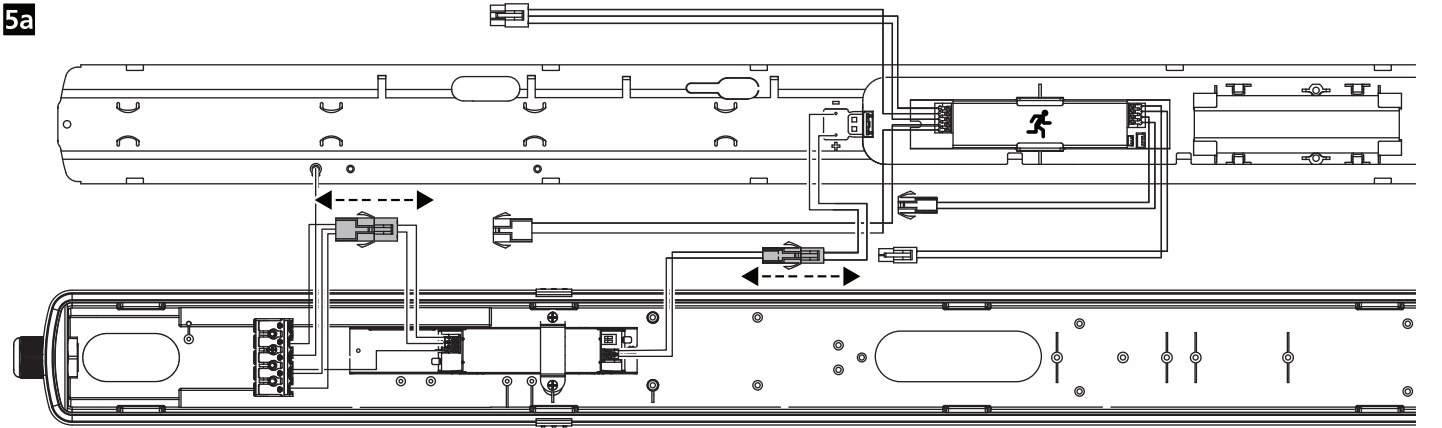

6a

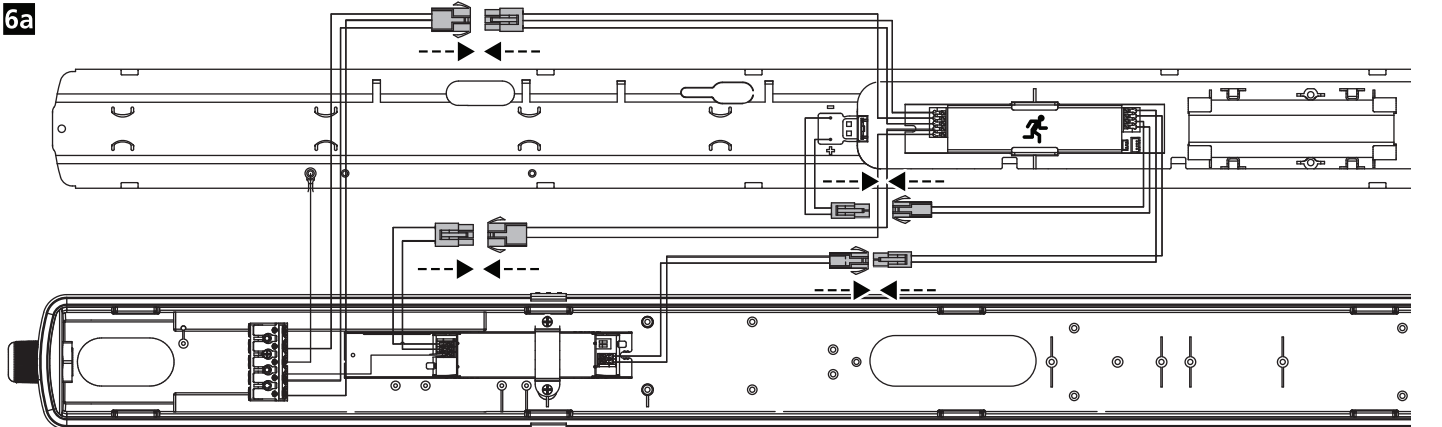

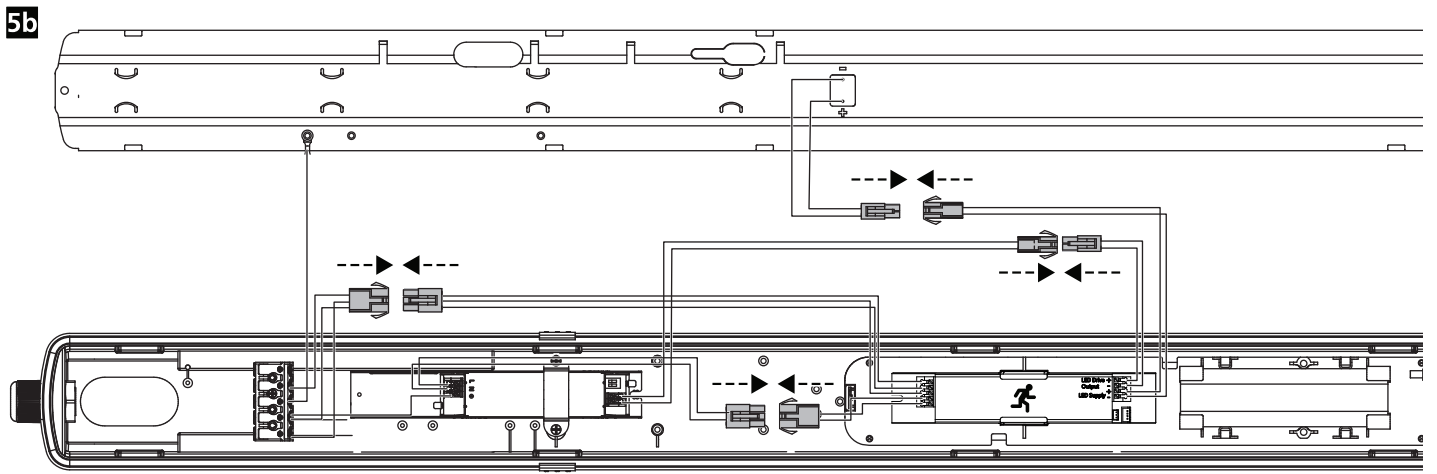
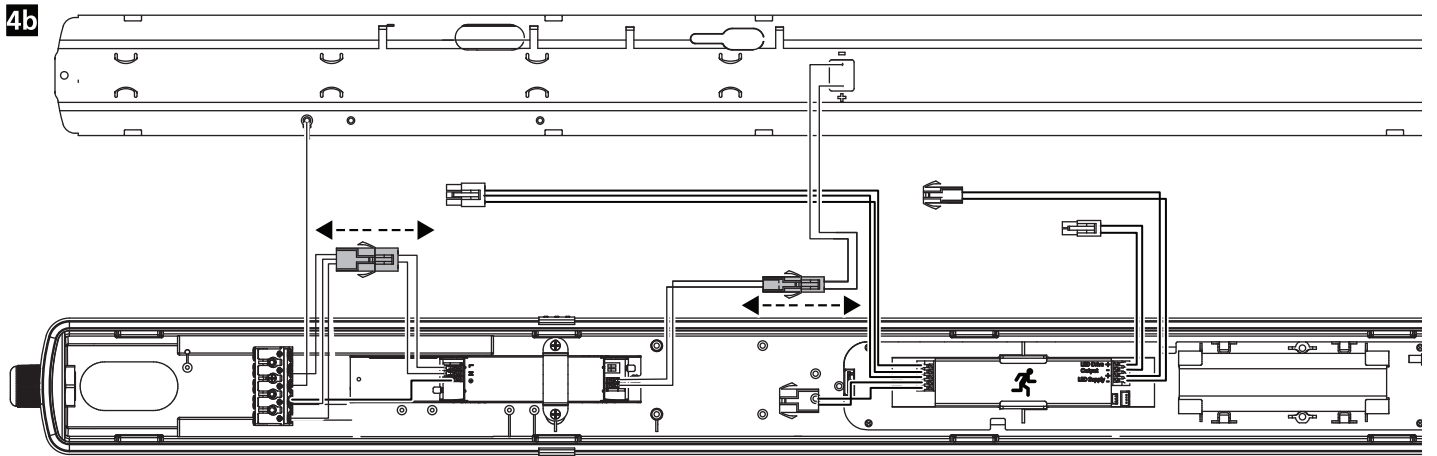
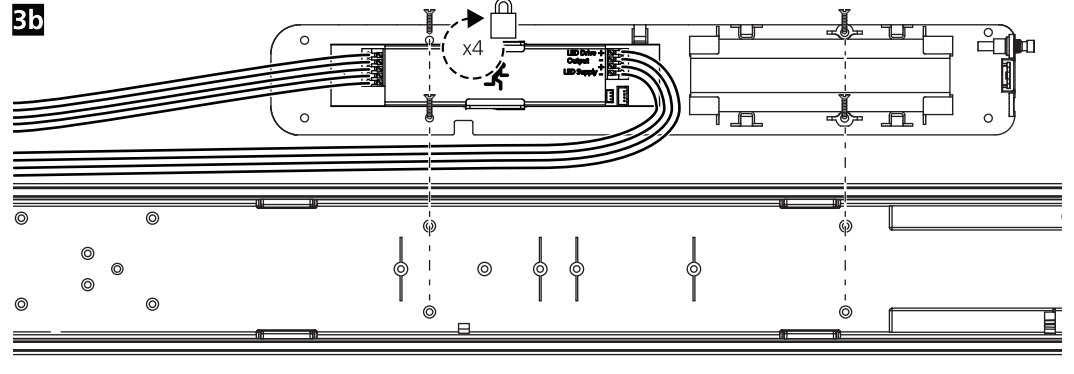
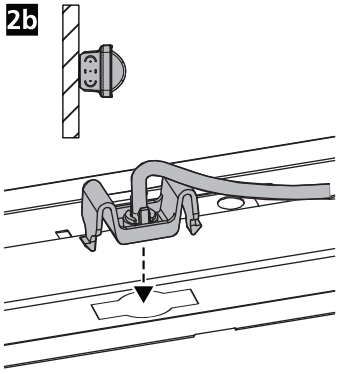

7

CYANTRONIC
 Rechargeable Lithium Iron
 Phosphate Battery Pack
21FpR19/66-2 4.0Ah 6.4V
 25,6 Wh
 Battery Part No.: 0101A000133
 Date of Installation: _____
 Made in P.R.C.

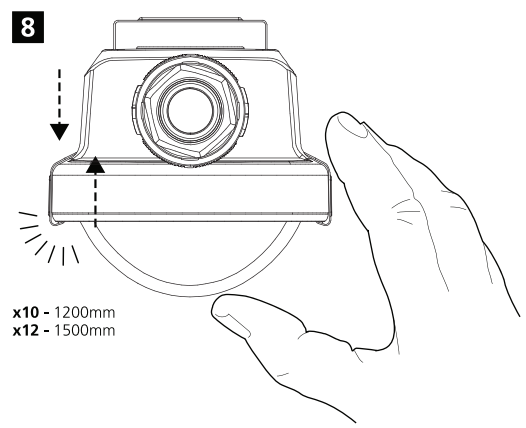

9

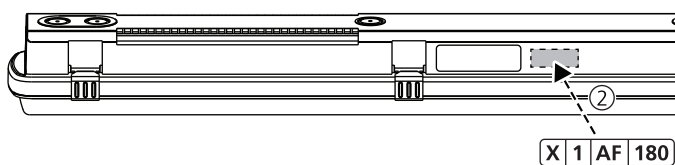

?   0010474 MW ON/OFF Kit  IS16578 Non-dim DALI

a

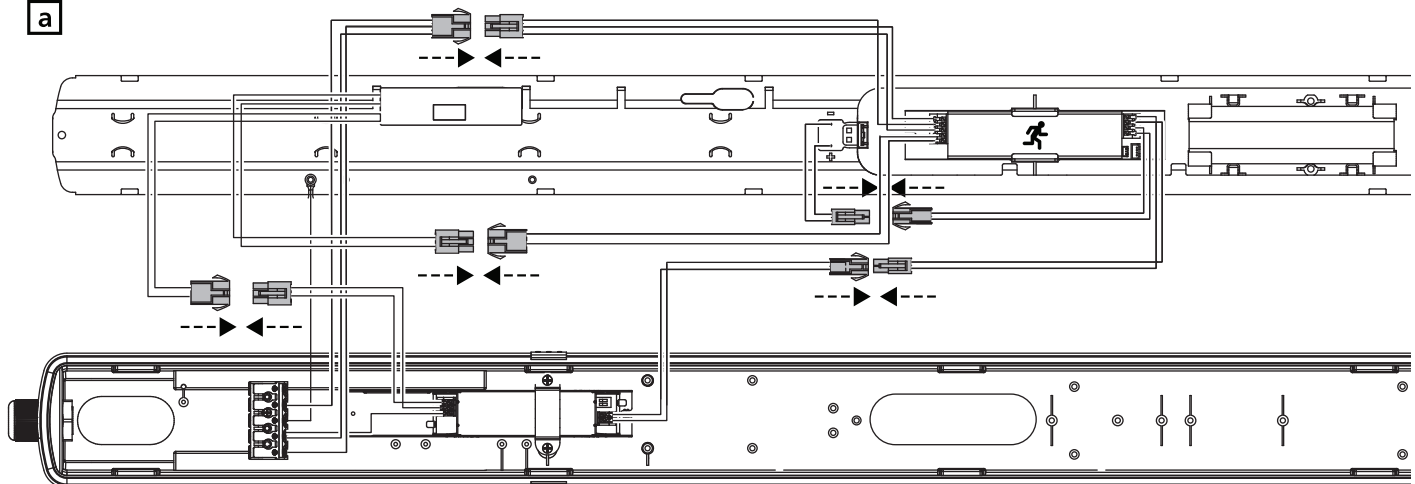

b

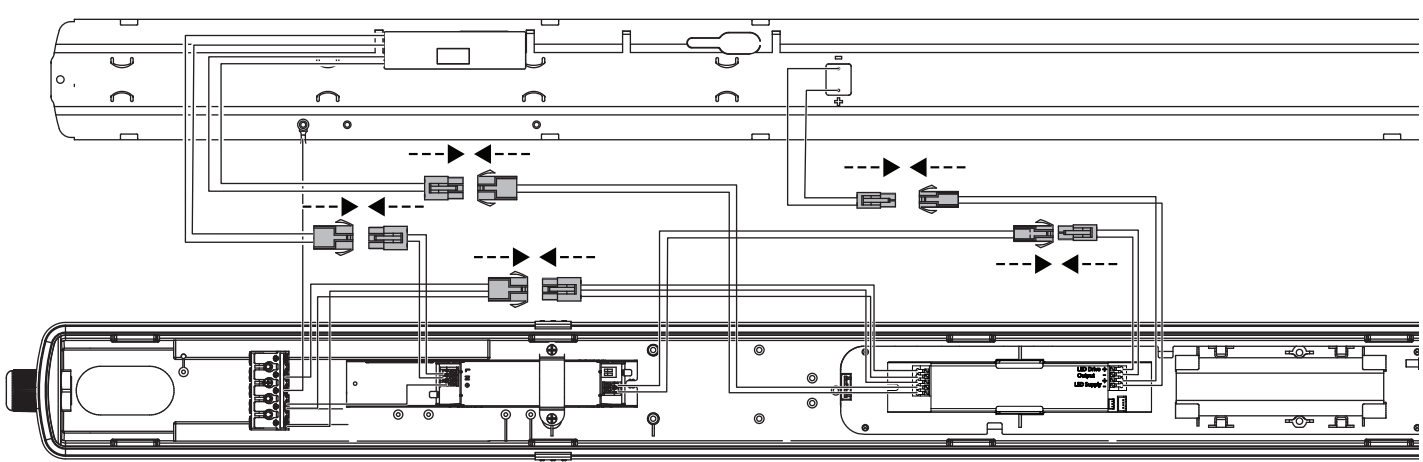

0010468 DALI Self Test EM kit

1

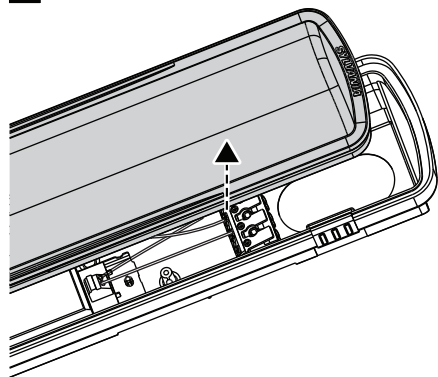

2a

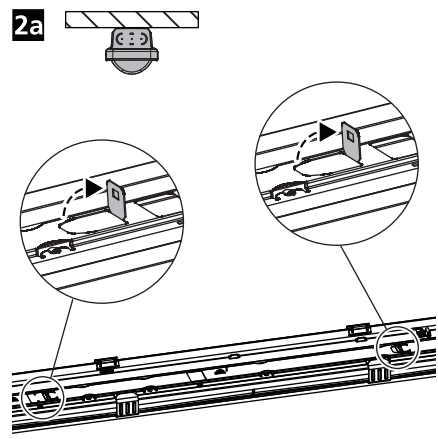

3a

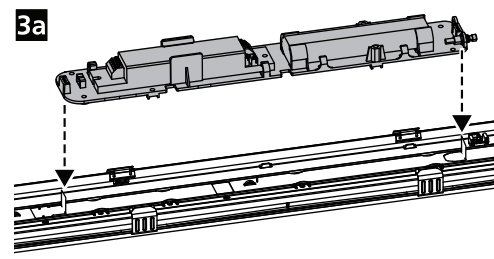

4a

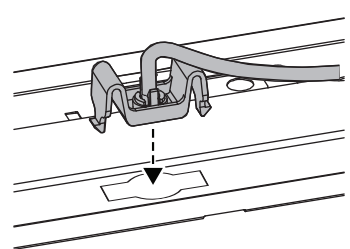

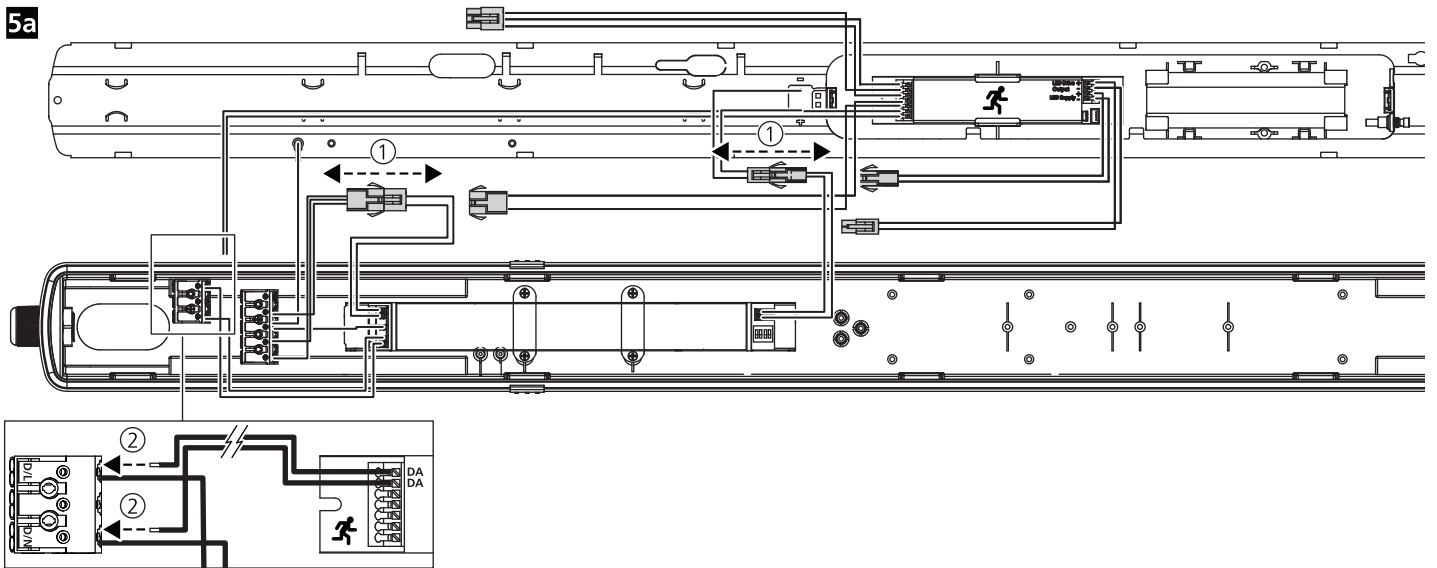
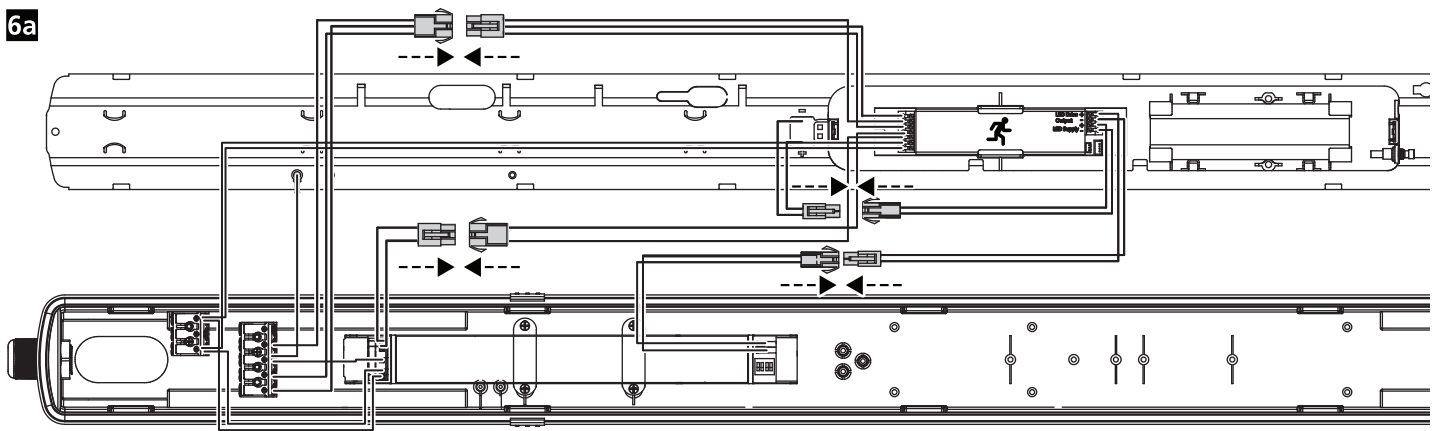
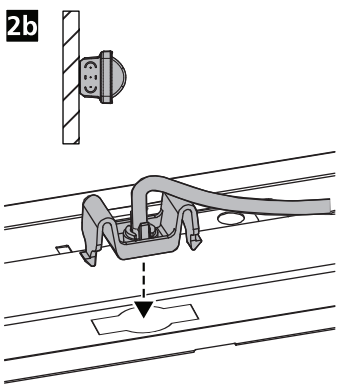
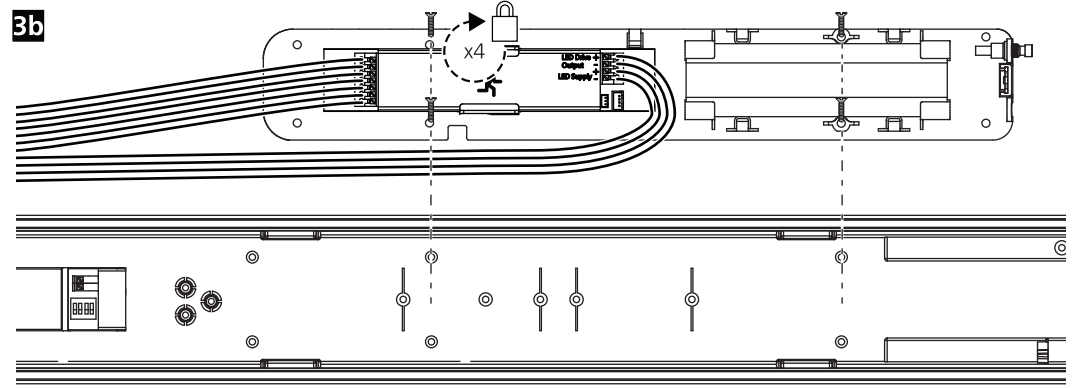
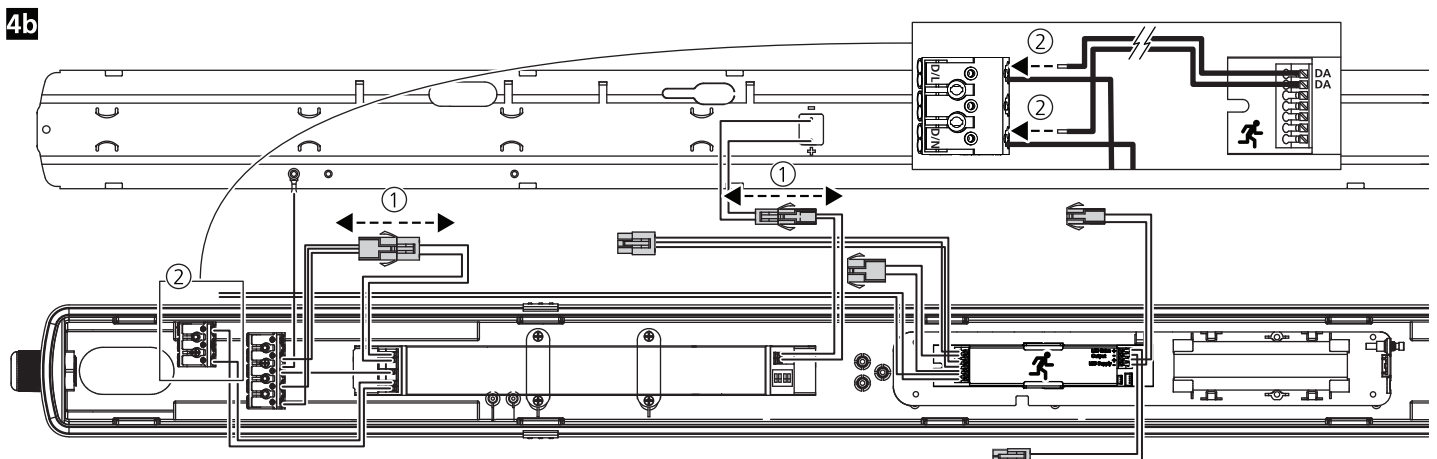
5a**6a****2b****3b****4b**

5b

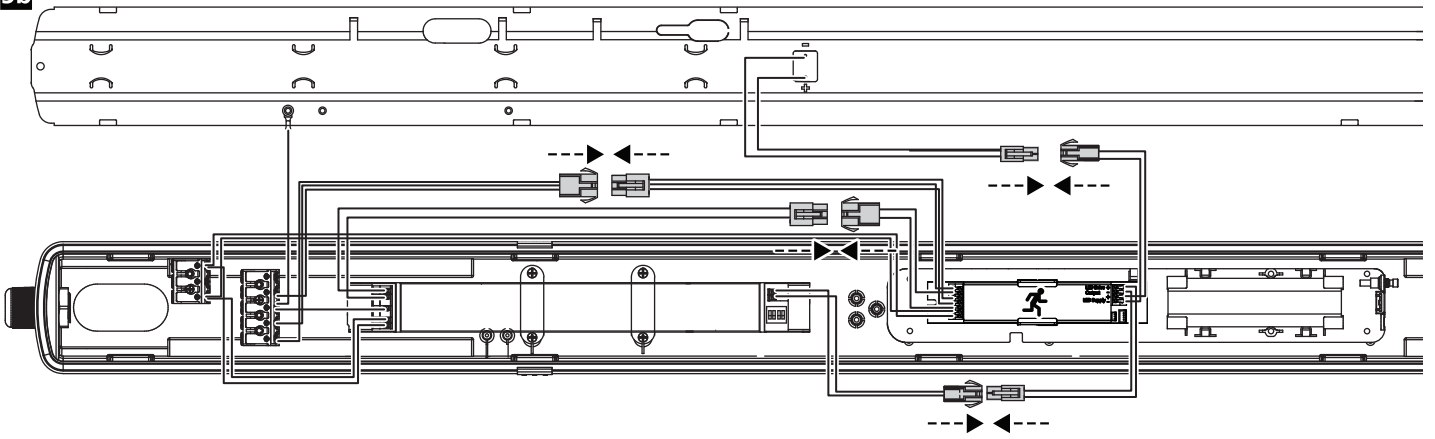

7

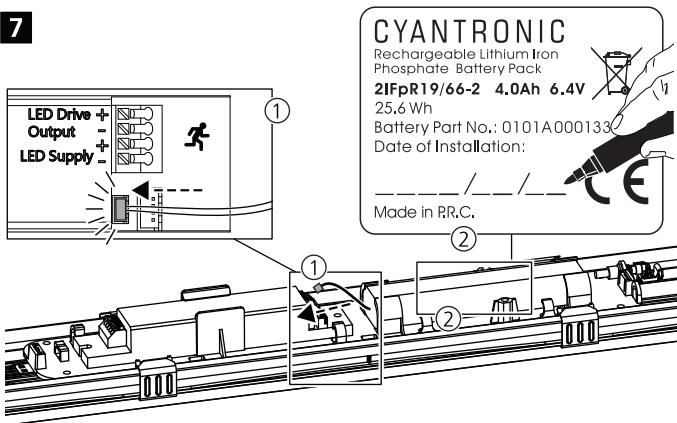

8

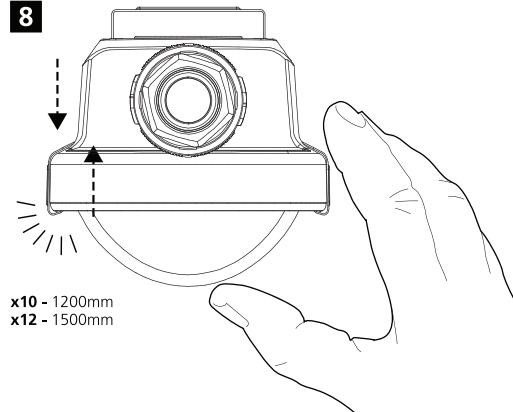

9

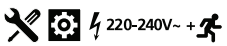
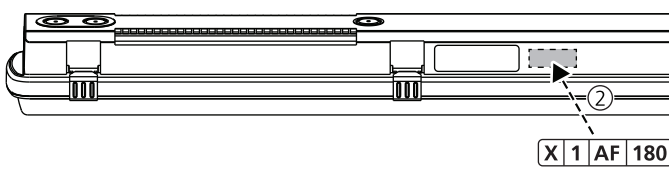

LED INDICATION		STATUS		DESCRIPTION
LED Colour	Status	Flashing		
		ON	OFF	
Green	●	∞	-	Battery Connected and Charging
	☼	0.1 sec	0.1 sec	Functional Test in Progress
	☼	0.5 sec	0.5 sec	Duration Test in Progress
Red	●	∞	-	Battery Fault
	☼	0.5 sec	0.5 sec	Battery Needs Replacing
	☼	0.1 sec	0.1 sec	Lamp Fault
Red/Green	●	-	∞	Emergency Mode

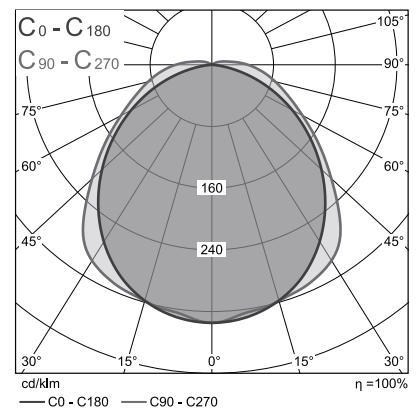

EM lm output = 800 lm

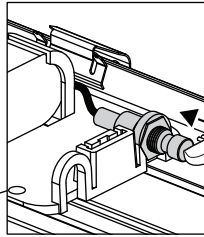
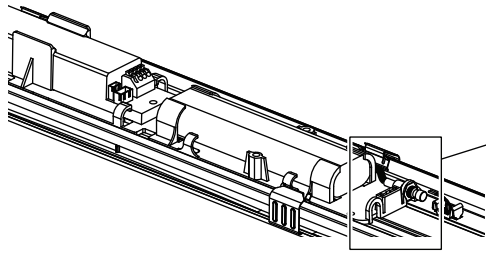
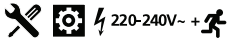

1-2 sec



Functional Test

5-10 sec



Duration Test



1

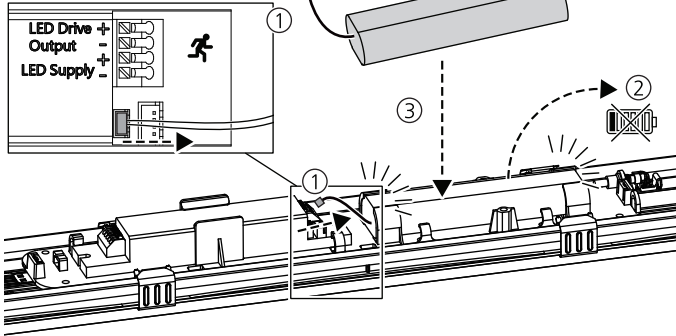

2

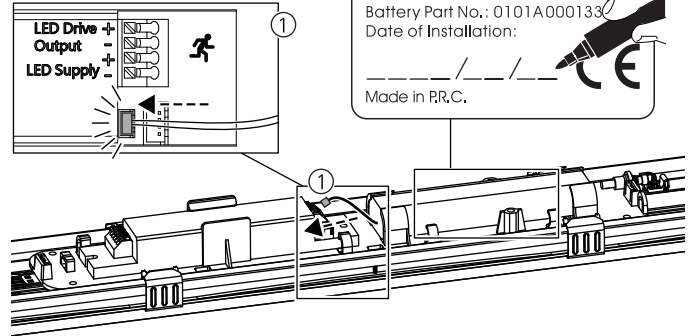

CYANTRONIC
Rechargeable Lithium Iron
Phosphate Battery Pack
21FpR19/66-2 4.0Ah 6.4V
25,6 Wh
Battery Part No.: 0101A000133
Date of Installation: _____
Made in P.R.C.

2

